

LB Lever Hoist

3/4, 1, 1 1/2, 2, 2 3/4, 3, 6, and 9 Ton Capacity

The LB Series of lever hoists offers a low headroom, compact design that is perfect for use in tight quarters. Regarded as the best lever hoist in the industry, our LB is recommended for use in heavy-duty construction work, mining, manufacturing, shipbuilding and day-to-day maintenance and repair.

Many Benefits from More Features:

- Rugged, all-steel construction that actually weighs less than comparable aluminum models.
- Get positive braking action with Weston-style load brake incorporating two moisture-resistant brake pads with four braking surfaces. Includes two brake pawls for additional reliability.
- Enjoy protection against dirt and moisture with a totally enclosed brake mechanism.
- Ensure long life with machined, heat-treated, split load double reduction gears.
- Operate in close quarters with short steel handle and 15-degree recovery strokes.
- Patented spring-loaded freewheel mechanism permits easy adjustment of the load chain and safeguards against accidental freewheeling under load.
- Equipped with standard rubber grip for non-slip operation.
- Powder-coated body is resistant to corrosion, chipping, fading and wear.

Options: (See page 31-32)

- Load limit warning handle
- Top hook extender
- Point load hook
- Slip clutch
- Inspection hook
- Bullard® and SmartLok™ hooks

Capabilities to Count On:

- 5-foot lift is standard, 10-, 15- and 20-foot lifts also stocked; nonstandard lifts available as well.
- Grade 100 heat-treated load chain is nickel-plated for corrosion resistance.
- Forged and heat-treated alloy steel hooks open slowly without fracturing under excessive loads. Top and bottom hooks rotate 360°.
- Test certificate verifies that every hoist has been factory load tested to 125% of rated capacity, in accordance with ASME B30.21 requirements.



LB LEVER HOIST — SPECIFICATIONS & DIMENSIONS

Cap. (Tons)	Product Code	Headroom C (in)	Std. Lift (ft)	Pull to Lift Load* (lbs)	a (in)	b (in)	D* (in)	e (in)	f (in)	g (in)	Load Chain Diameter (mm) x Chain Fall Lines	Net Weight (lbs)	Shipping Weight Approx. (lbs)	Weight for Additional One Foot of Lift (lbs)			
3/4	LB008	11.0	5	54 (36)	5.7	4.7	9.6 (14.4)	3.8	1.6	0.9	5.6 x 1	13	14	0.5			
1	LB010	11.8		72 (46)						1.1							
1 1/2	LB015	13.2		64 (45)	6.3	5.0	10.4 (14.4)	3.9	1.5	1.3	7.1 x 1	18	19				
2	LB020	14.8		59 (42)	6.8	5.9									4.0	1.8	1.4
2 3/4	LB028			81 (57)													
3	LB030	15.6		69	7.5	6.3	16.3 (16.9)	4.4	2.3	2.0	10.0 x 1	33	35				
6	LB060	21.3		72		8.5									10.0 x 2	58	60
9	LB090	26.8		78		12.0											

*Figures in parentheses are for hoists with the optional load limit warning handle.

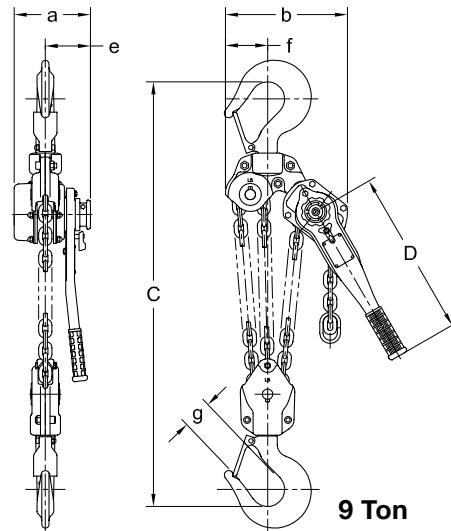
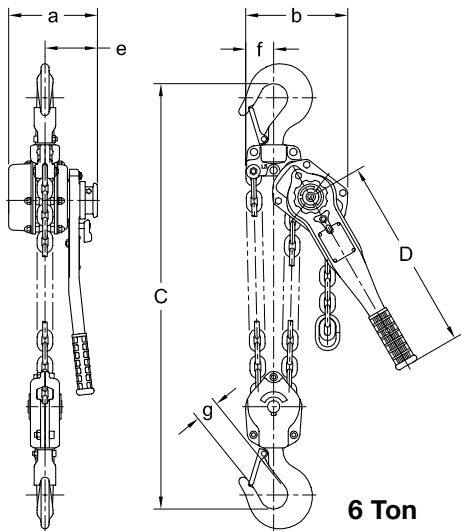
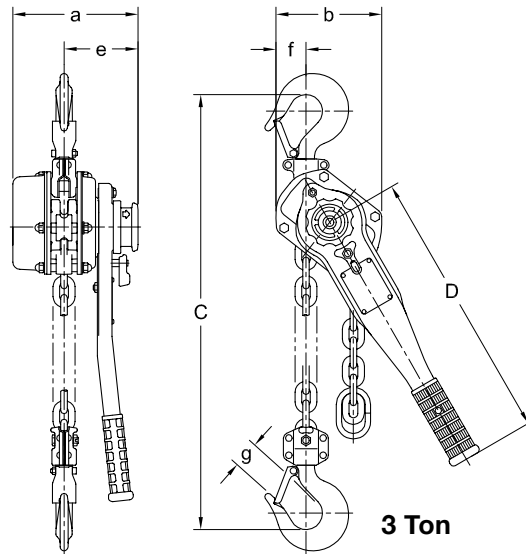
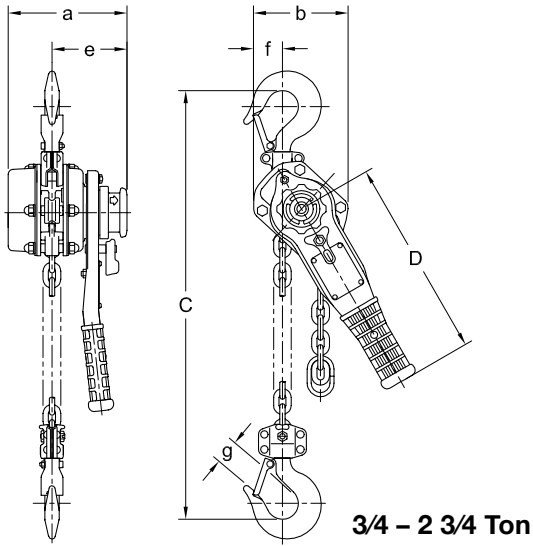

LB Lever Hoist

LB Designs and Capacity for Every Application



*Single chain
fall line
3 1/4-3 Ton*



*Double chain
fall line
6 Ton*

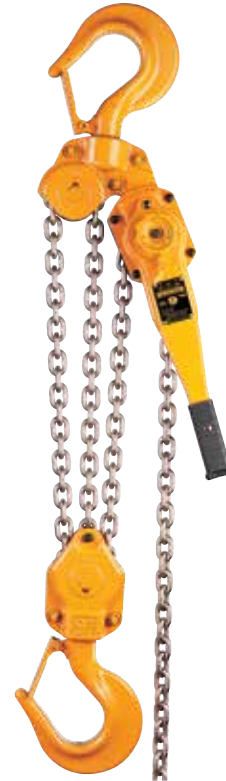

*Triple chain
fall line
9 Ton*

Industry's First 2 3/4 Ton Capacity Lever Hoist

Created for industrial applications where 3 Ton is too much and 2 Ton is not enough.



LX Lever Puller

1/4 and 1/2 Ton Capacity

Harrington's LX mini puller is lightweight, compact and built to perform. It fits conveniently in a toolbox and will easily handle pulling and moving jobs in many applications including transportation, construction and plumbing. Available in two capacities to fit all applications. The 1/2 Ton capacity is unique to the industry.

Many Benefits from More Features:

- Durable die-cast aluminum body with steel frame is compact and lightweight.
- Very low headroom design for use in tight spaces.
- Free-chain mechanism allows for quick adjustments.
- Extremely low pulling force is required for operation.
- Weston-style brake is totally enclosed to protect against dirt, dust and rain.
- Single step reduction gear assures load holding performance.
- Load chain guide mechanism permits smooth and quiet guiding of chain.
- Rubber handle grip for ease of use.
- Effortless to transport, install and store.
- Powder-coated body is resistant to corrosion, chipping, fading and wear.

Options: (See page 32)

- Heavy duty carrying case

Capabilities to Count On:

- Grade 100, nickel-plated load chain is corrosion and wear resistant.
- Strong hook latches include notched tip.
- 5-foot lift is standard. Longer lifts are available in both capacities.
- Sold individually or in convenient multi-packs— 1/4 Ton in 6-packs and 1/2 Ton in 4-packs.
- Test certificate verifies that every hoist has been factory load tested to 125% of rated capacity in accordance with ASME B30.21 requirements.



1/4 Ton

1/2 Ton

LX LEVER PULLER — SPECIFICATIONS & DIMENSIONS

Cap. (Tons)	Product Code	Headroom C (in)	Std. Lift (ft)	Pull to Lift Load (lbs)	a (in)	b (in)	D (in)	e (in)	g (in)	Load Chain Diameter (mm) x Chain Fall Lines	Net Weight (lbs)	Shipping Weight Approx. (lbs)	Weight for Additional One Foot of Lift (lbs)
1/4	LX003	8.1	5	40	3.4	2.9	5.9	2.4	0.8	3.2 x 1	3.5	4.0	N/A
1/2	LX005	9.7		62	3.9	3.7	7.1	2.6	0.9	4.3 x 1	5.7	6.2	0.25

Weights are approximate.

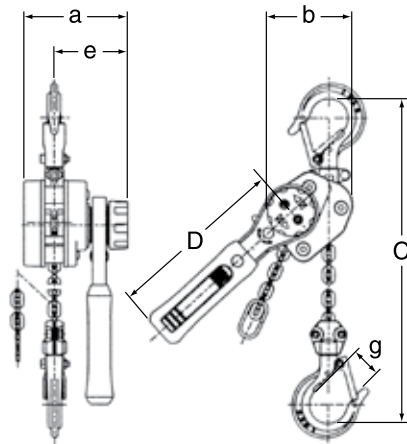

1/4 Ton LX

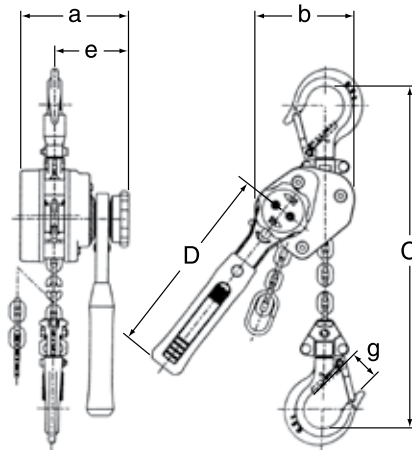

1/2 Ton LX